

**Identify terminals, parts and DC connections of different types of DC machines**

**Objectives:** At the end of this Exercise you shall be able to

- read and interpret the name-plate details of the given DC machine
- determine the pairs of terminals of the windings of the DC machine by the test lamp method
- test and identify the field and armature terminals of DC machine by the test lamp method
- Identify the parts of DC machines
- connect different types of DC machines.

Requirements	
<b>Tools/Instruments</b> <ul style="list-style-type: none"> <li>• Insulated combination pliers 200mm - 1 No.</li> <li>• Screwdriver 150mm - 1 No.</li> <li>• D.E. spanner set 5mm to 20mm (For a group of seven) - 1 No.</li> </ul>	<b>Materials</b> <ul style="list-style-type: none"> <li>• P.V.C. Insulated cable 3/20 of 660 V grade - 5 m</li> <li>• Kit-kat fuse unit 250V, 16A - 1 Set</li> <li>• Pendant lamp-holder 240V, 6A - 1 No.</li> <li>• S.P.T. switch 240V, 6A - 1 No.</li> <li>• B.C. lamp 25/40 watt, 240V - 1 No.</li> <li>• Fuse wire 5A - as reqd.</li> <li>• Cleaning cloth - as reqd.</li> </ul>
<b>Equipment/Machines</b> <ul style="list-style-type: none"> <li>• DC compound machine 220V or 440V rating - 1 No.</li> <li>• Dismantled DC machine - 1 No.</li> </ul>	

**PROCEDURE**

**TASK 1: Read and interpret the name plate details and identify the terminals of a DC compound machine**

- 1 Read the name-plate details of the given DC compound machine and record them in Table.
- 2 Remove the terminal box cover and sketch the layout of the terminals by yourself.

**Do not spoil screw heads or nuts nor lose them while removing the terminal cover.**

**As there is no marking on the terminals, give your own marking.**

**TASK 2: Test and identify the pairs of terminals of a DC compound machine**

- 1 Prepare a test lamp for 240V 25W.
- 2 Connect Probe 1 of the test lamp to terminal 1 and touch the other Probe 2 to the rest of the terminals, one by one. (Fig 1)
- 4 Connect Probe 1 of the test lamp to another terminal as shown in Fig 1 and repeat the procedure of steps 2 and 3 to find the second pair of terminals and write the results in Table 1.

Table 1

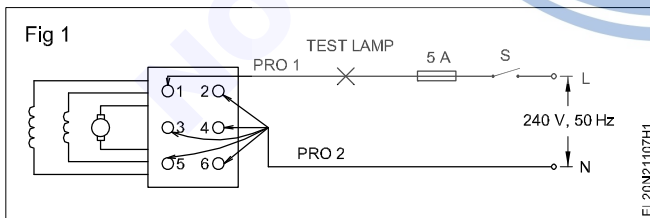

Sl. No.	Pairs of terminals	Condition of lamps	Identification
1	1 and 2		
2	1 and 3		

- 3 Check the condition of the lamp.

**If the lamp glows (Fig 1) while touching any one of the other terminals, then the terminal connected to Probe 1 and Probe 2 form pairs of the same circuit. Record the observations in Table 1.**

**The test lamp glows bright in both armature and series field terminals as the respective inductive reactance are of low value, whereas in the shunt field circuit the light may glow dim, or probes when touched, may give some spark only due to high inductive reactance therein.**

## Conclusion

Armature terminals \_\_\_\_\_ and \_\_\_\_\_  
(Mark them as  $A_1$  &  $A_2$ .)

Shunt field terminals \_\_\_\_\_ and \_\_\_\_\_  
(Mark them as  $E_1$  &  $E_2$ .)

Series field terminals \_\_\_\_\_ and \_\_\_\_\_  
(Mark them as  $D_1$  &  $D_2$ .)

- 5 Check the other two left out terminals, to ascertain whether they belong to the same pairs of terminals.

The pairs of terminals in which the lamp either glow dim or the prod contact point gives spark as shown in Fig 2 form the shunt field terminals.

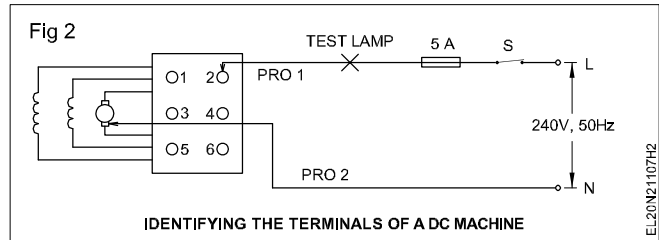

**Note:** You might have observed in this experiment the lamp glows rather brightly at two sets or pairs of terminals. They belong to the armature and series fields. To distinguish the pair of armature terminals out of the two pairs, follow the steps as given in Task 3.

### TASK 3: Identify the armature terminals pair out of 2 pairs of low resistive terminals

- 1 Connect probe 1 to any one of the identified low resistive (where lamp was glows bright) pairs. (Fig 2)
- 2 Touch probe 2 to any one of the brushes. (Fig 2)

Take care that the probe does not touch the body/frame of the machine or any other metal part except the brush.

- 3 If the test lamp glows, then that pair belongs to the armature terminals. If not, try the other pairs. Mark the terminals as  $A_1$  and  $A_2$  in and also enter in Table 1.
- 4 The remaining two terminals will be of series field terminals. Mark them as  $D_1$  and  $D_2$  and also enter in Table 1.
- 5 Show the results to your instructor.

### TASK 4: Identify the parts of DC machines

- 1 Read and interpret the name plate details of the DC machine.
- 2 Identify the parts of the DC machine.

- 3 Put the label on each parts with numbers. (Fig 1)
- 4 Record the name of the parts and draw the sketches of each parts in your notebook

### TASK 5 : Identify terminals and connect DC shunt generator

- 1 Connect the machine as per the connection diagram. (Fig 1)
- 2 Connect field winding to the armature terminal in parallel. (Fig 1)

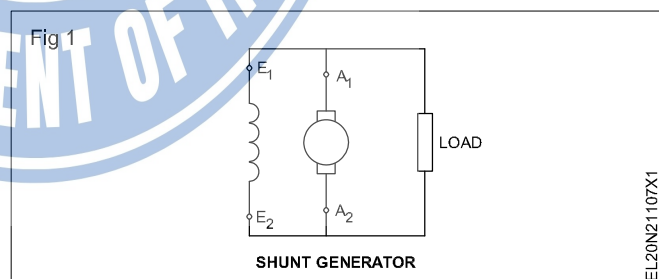

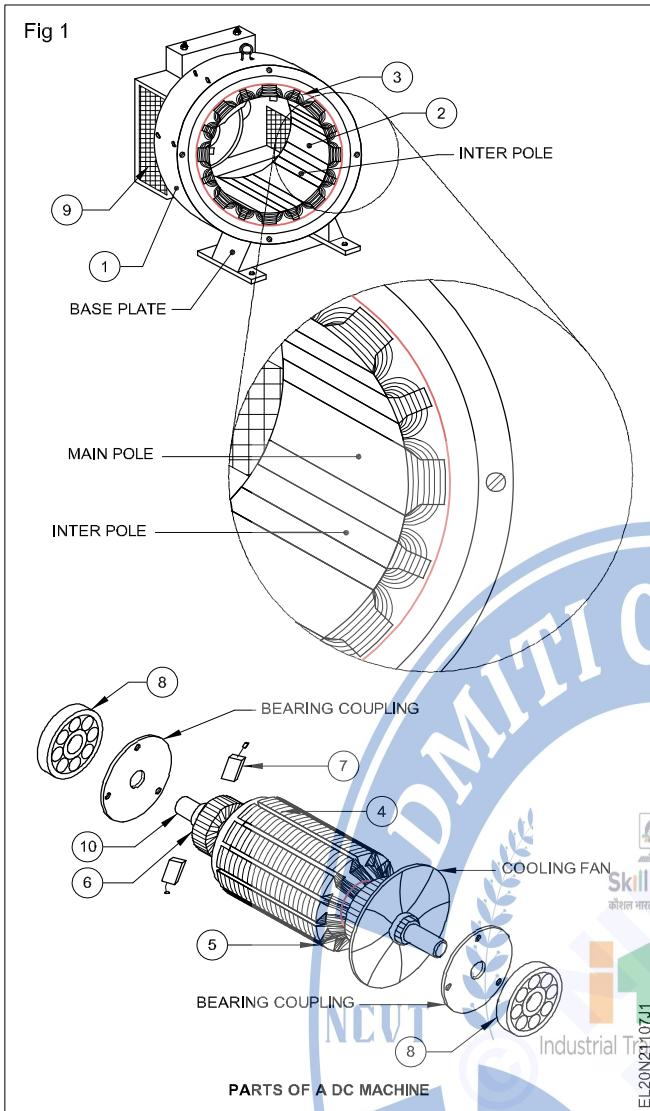

**TASK 6 : Identify terminals and connect DC series generator**

- 1 Connect the machine as per the connection diagram. (Fig 1)
- 2 Connect field winding in series with the armature. (Fig 1)

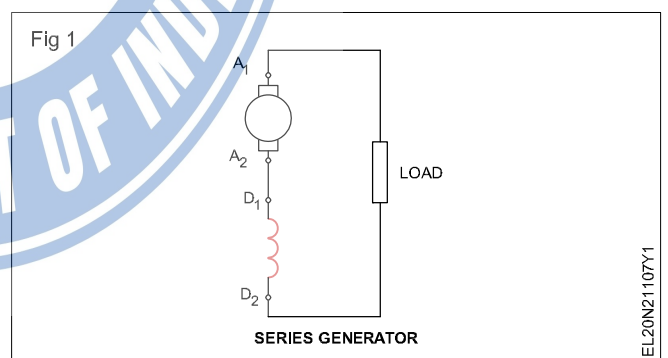

**TASK 7 : Identify terminals and connect various DC compound generator**

- |   |   |
|---|---|
| <ol style="list-style-type: none"> <li>1 Connect the machine as per the connection diagram (Fig 1).</li> <li>2 Provide the field excitation by a combination of shunt and series field windings.</li> </ol> | <ol style="list-style-type: none"> <li>3 Connect the shunt field directly across the armature (Fig 1).</li> <li>4 The shunt field is connected in parallel with the series combination of armature and series field. (Fig 2)</li> </ol> |
|---|---|

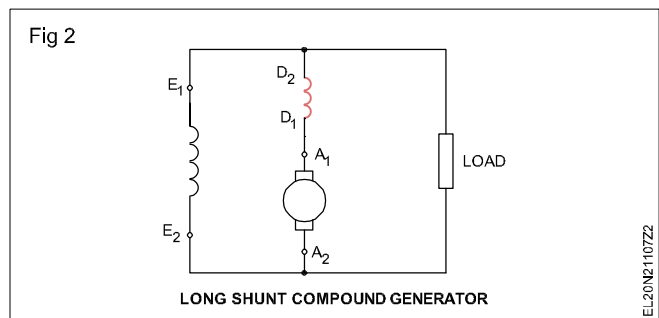
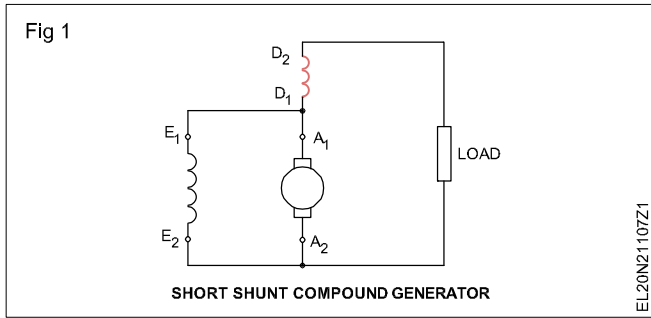

5 Connect the machine as per the connection diagram for short shunt cumulative compound and short shunt differential compound generator.

6 Connect the machine as per the connection diagram for differential long shunt cumulative compound and long shunt differential compound generator.



**Measure field and armature resistance of DC machines**

**Objectives:** At the end of this Exercise you shall be able to

- measure the shunt field resistance of a DC machine by the voltmeter and ammeter method
- measure the shunt field resistance of a DC machine by the ohmmeter method and compare the results
- measure the armature resistance using a voltmeter and ammeter
- measure and verify armature resistance by the ohmmeter method.

Requirements	
<b>Tools/Instruments</b>	<b>Equipment/Machines</b>
<ul style="list-style-type: none"> <li>• Screwdriver 150 mm - 1 No.</li> <li>• Insulated combination pliers 150 mm - 1 No.</li> <li>• D.E. spanner set 5mm to 18mm - 1 Set</li> <li>• M.C. voltmeter 0 to 25V - 1 No.</li> <li>• M.C. ammeter 0 to 100 milli-amperes - 1 No.</li> <li>• Series/ shunt type ohmmeter 0-50 ohms - 1 No.</li> <li>• M.C. ammeter 0 to 5A - 1 No.</li> <li>• M.C. voltmeter 0 to 500V - 1 No.</li> </ul>	<ul style="list-style-type: none"> <li>• Car battery 24V, 100 AH - 1 No.</li> <li>• Rheostat 250 ohms, 1 ampere - 1 No.</li> <li>• DC compound machine 220V/ 3KW - 1 No.</li> <li>• Rheostat 10 ohm 5 A - 1 No.</li> </ul>
	<b>Materials</b>
	<ul style="list-style-type: none"> <li>• PVC Insulated copper cable 1.5 sq mm - 5 m</li> <li>• Crocodile clips 16A - 4 Nos.</li> <li>• Test lamp - 1 No.</li> </ul>

**PROCEDURE**

**TASK 1: Measure the shunt field resistance by the voltmeter and ammeter method**

- 1 Connect the circuit as per Fig 1 and get the approval of the instructor.

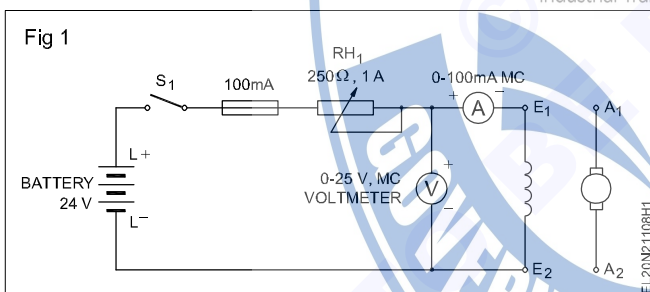
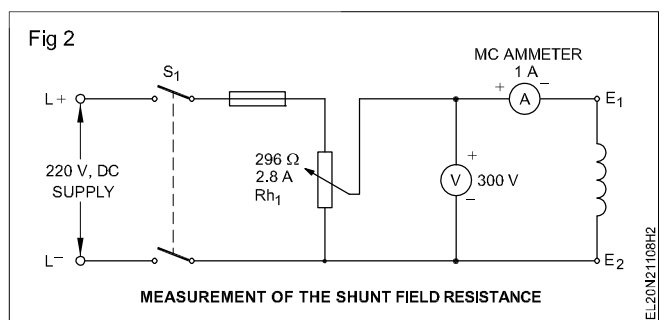

Table 1

Sl. No.	mA	Volts	$R_{sh} = V/mA$ K ohms ( $R = V/I$ )	Average value shunt field resistance in ohms
1	20			
2	40			
3	60			
4	80			
5	100			

- 2 Switch 'on' the circuit and adjust the rheostat to get 20 mA.
- 3 Read and record the voltmeter and milli-ammeter readings in Table 1.
- 4 Repeat steps 2 and 3 for 40, 60, 80 and 100 mA current ratings.
- 5 Switch off the circuit and complete the tabular columns.
- 6 Calculate the average value of the field resistance and show it to the instructor.
- 7 Disconnect the circuit after getting the approval by the instructor.

**If the specified range of meters or supply is not available, it can be carried out, as shown in Fig 2, by using suitable meters and 220V DC.**



**TASK 2: Measure shunt field resistance by an ohmmeter**

- 1 Take a series type ohmmeter or multimeter; select a proper ohmic range and set its value to zero by shorting the prods.

**Use a series type ohmmeter to measure high value resistance.**

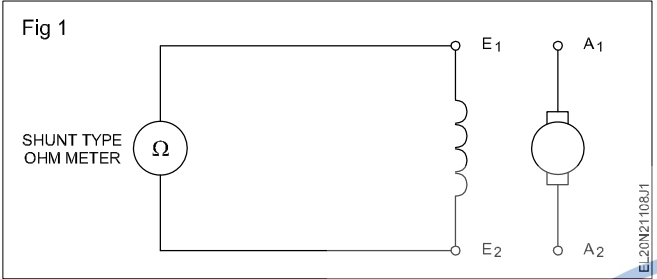

- 2 Connect the meter leads to the shunt field terminals of the machine as per the Fig 3.
- 3 Read, and record the value of the shunt field resistance below. The value of the shunt field resistance is \_\_\_\_\_ ohms.
- 4 Refix the terminal cover.
- 5 Compare the readings obtained in Tasks 1 and 2. If there is any difference write the reasons in the space given below.

---



---



---

**TASK 3: Measure the armature resistance using a voltmeter and ammeter**

- 1 Connect the armature terminals to the ammeter, voltmeter, fuses, rheostat Rh<sub>1</sub> and the battery. (Fig 4)

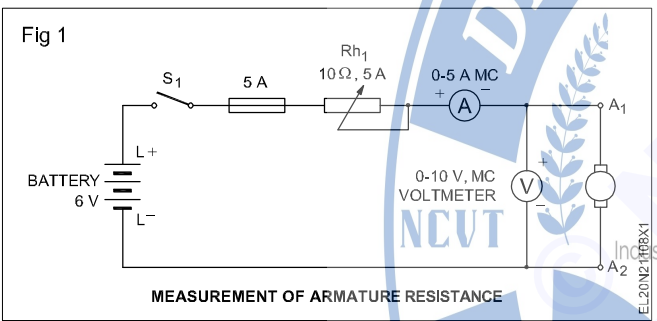

- 4 Read and record the volt and ammeter readings in Table 2.

- 2 Keep the rheostat Rh<sub>1</sub> in cut 'in' position. Then switch 'on' the circuit.

**Sometimes the armature starts rotating slowly during the experiment. In such cases hold the armature in a steady position by hand to avoid erroneous reading.**

- 3 Adjust the reading of the ammeter to 0.5 amperes by adjusting Rh<sub>1</sub>.

**Move the armature to different positions by hand and see that the reading remains constant.**

Table 2

Slja No.	Amps.	Volts	R = V/I	Average Value of armature resistance
1	0.5			
2	1			
3	1.5			
4	80			
5	100			

- 5 Repeat steps 3 and 4 for 1, 1.5, 2 and 2.5 amperes current ratings.
- 6 Switch 'OFF' the circuit.
- 7 Complete the remaining columns of the table, find the average value of the armature resistance and show the results to the instructor.
- 8 Disconnect the circuit after getting by the approval of the instructor.

**TASK 4: Measure armature resistance using an ohmmeter**

1 Adjust ohms 'Zero' and ohms 'Infinity' of the ohmmeter.

**Use a shunt type ohmmeter to measure the low value resistance of the armature.**

2 Connect the ohmmeter across the armature terminals (Fig 5) and measure the resistance.

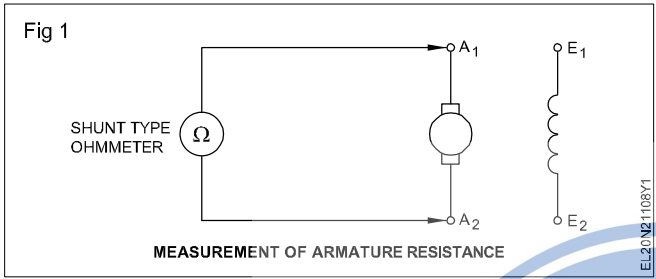

**Move the armature to different positions by hand and see that the reading remains constant.**

3 Note down the meter reading and record it below.

Armature resistance value is \_\_\_\_\_ ohms.

4 Replace the terminal cover and keep all tools, equipment and meters at their places.

5 Compare the readings of Task 2 & 3. If there is any difference, find the reasons for that and write your conclusions in the space below.

6 Conclusion

---

---

---



**Determine build up voltage of DC shunt generator with varying field excitation and performance analysis on load**

**Objectives:** At the end of this Exercise you shall be able to

- measure the voltage due to residual magnetism or create residual magnetism, if necessary
- measure the speed of a DC shunt generator with the help of a revolution counter and stopwatch
- build up voltage in a self-excited DC shunt generator
- determine the relation between field current and induced emf (magnetisation characteristic) in a DC shunt generator when the speed is constant
- connect a DC shunt generator and build up the voltage
- load the DC shunt generator
- determine the load performance characteristic of the DC shunt generator at different loads.

Requirements	
<b>Tools/Instruments</b>	<b>Equipment/Machines</b>
<ul style="list-style-type: none"> <li>• Combination pliers 200mm - 1 No.</li> <li>• Screwdriver 150mm - 1 No.</li> <li>• Electrician's knife 100mm - 1 No.</li> <li>• Revolution counter 4 digits - 1 No.</li> <li>• Stopwatch - 1 No.</li> <li>• Ammeter MC 0-1A - 1 No.</li> <li>• Voltmeter MC 0-300V - 1 No.</li> <li>• M.C ammeter 0-20A - 1 No.</li> </ul>	<ul style="list-style-type: none"> <li>• DC shunt generator 2 or 4 KW 220V - 1 No.</li> <li>• Rheostat 296 ohms 2.8 Amps - 1 No.</li> <li>• Knife switch D.P.S.T. 16A - 1 No.</li> <li>• Knife switch S.P.S.T. 16A - 1 No.</li> <li>• Lamp load 220v/5kw - 1 No.</li> </ul>
	<b>Materials</b>
	<ul style="list-style-type: none"> <li>• P.V.C. Insulated cable 2.5 sq.mm - 5 m</li> <li>• Fuse wire 10 A - 0.2 m</li> <li>• P.V.C Insulated flexible cable 14/0.2 - 2 m</li> </ul>

**PROCEDURE**

**TASK 1: Build up voltage of a DC shunt generator**

1 Connect the circuit as per Fig 1.

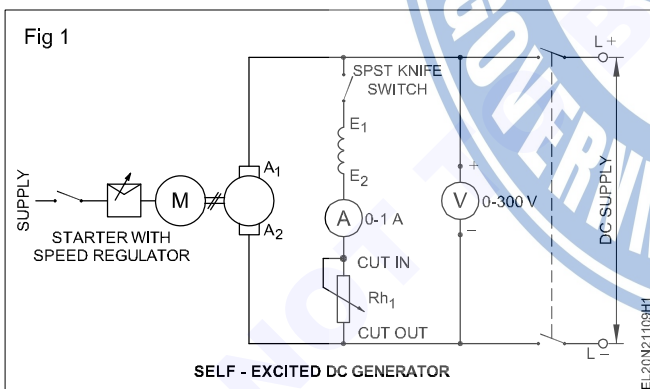

- 2 Keep the field switch open and the field rheostat in the cut 'in' position. Get the approval of the instructor.
- 3 Start the prime mover coupled to the DC shunt generator.

**The direction of rotation must be according to the direction marked on the DC generator. If not, change the direction of the rotation of the prime mover.**

4 Measure the speed of the generator with the help of the revolution counter and stopwatch.

**The number of revolutions made by a machine in a minute gives the r.p.m.**

5 Adjust the prime mover speed such that the generator runs at its rated speed.

**Keep the speed constant throughout the experiment.**

6 Measure the voltage induced across the armature and note down the measured value in Table 1.

**This induced voltage is due to the residual magnetism as the field current is zero. If the residual magnetism is absent in the field poles, then there will be no residual voltage. In such a case the residual magnetism could be recreated by connecting the field winding to a DC source such as a battery for a short time.**

7 Close the field circuit switch and gradually increase the field current to 0.1 ampere by reducing the resistance of the field rheostat.

**If the generator is not able to build up voltage even though it is running in the marked direction, switch off the prime mover and then**

interchange the field terminals of the generator. While varying the field rheostat/regulator it should be done positively and slowly in the forward direction. Reverse movement should be avoided.

- 8 Increase the field current slowly in steps of 0.1 ampere, and for each step, note down the field current and the corresponding induced voltage. Record them in Table 1.

**Increase the field current only till the induced voltage reaches just above 125% of the rated**

value. Check the speed of the generator at intervals. If necessary, adjust it to the rated value.

- 9 Switch 'OFF' the DC generator and the prime mover.  
10 Draw the graph keeping the induced voltage in the 'Y' axis and the field current in the X axis.

**The graph shows the magnetisation / no-load characteristic of the DC shunt generator.**

- 11 Show your readings and graph to your instructor.

Table 1

Sl. No.	Field current in amps	Induced voltage in volts	Speed (held at constant rated value throughout the experiment)

## Skill Sequence

### Method of using a tachometer

**Objective:** This shall help you to  
• measure speed using a tachometer.

A hand tachometer (Fig 1) is a portable instrument and is used for measuring the speed of the rotating machinery.

If the reading is within a lower speed range, use the next lower range to take a new reading for a more accurate result.

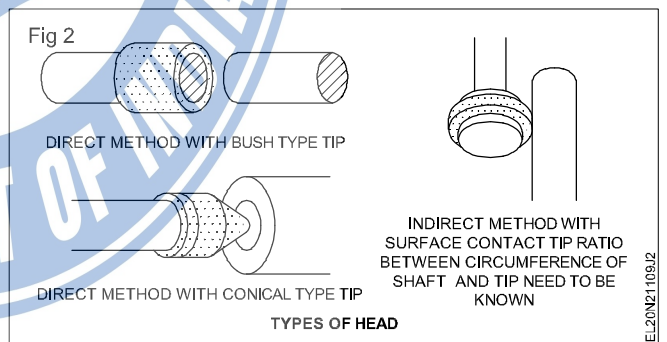
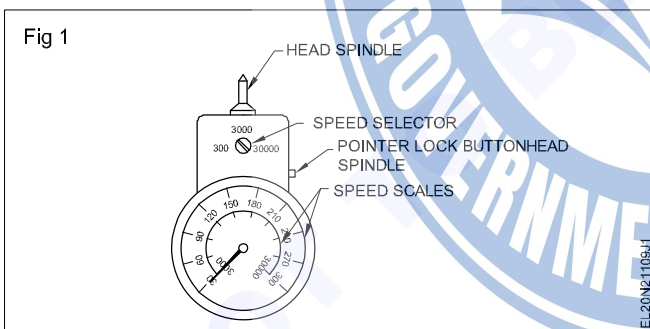

#### To use a hand tachometer (Fig 2)

- Select and fit the correct head
- Select the highest speed range on the tachometer if the speed is not known.
- Hold the tachometer gently against the shaft.
- Depress the pointer lock button when the pointer has settled. (Fig 3)
- Remove the tachometer from the shaft to take a reading.
- Take a reading using the correct scale for the speed range.

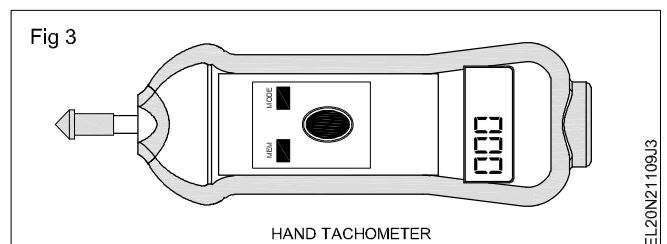

**TASK 2 : Determine performance analysis of DC shunt generator on different loads**

- 1 Measure the armature resistance and enter the value in Table 1.
- 2 Select appropriate cables, switch, load and meters, according to the capacity of the given DC shunt generator.
- 3 Connect the meters, rheostat and lamp load with the terminals of the DC shunt generator (Fig 1). (If a lamp load is not available, a water load can be used.)
- 4 Keep the load switch open and also switch 'off' all the circuit switches in the lamp load.

- 5 Keep the field regulator resistance in 'cut-in' position.

**Make yourself clear about the method of starting the prime mover and the procedure of adjusting its speed.**

- 6 Start the prime mover and bring it to the rated speed of the generator.
- 7 By adjusting the field rheostat, build up the voltage of the generator to its rated value. Enter the value of the open circuit voltage in Table 1.

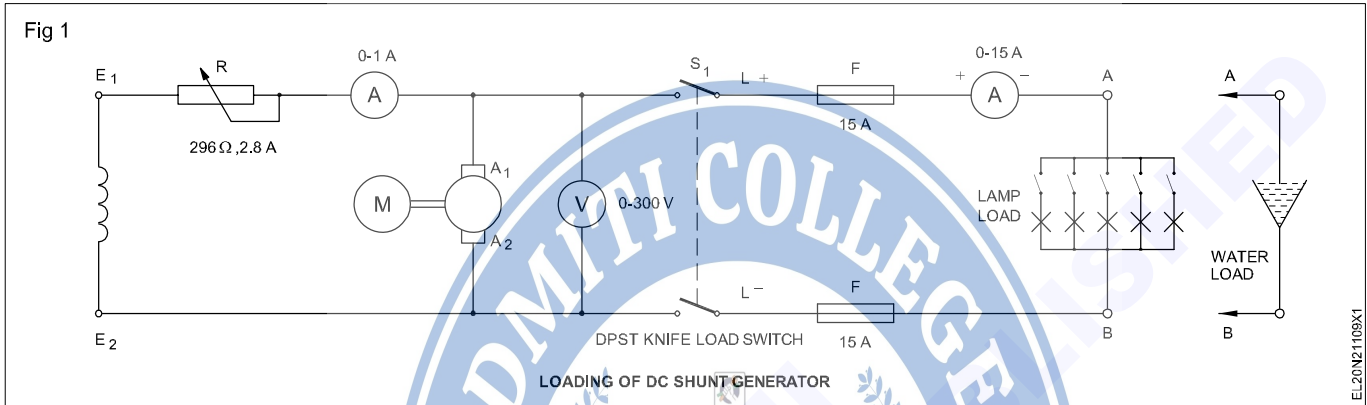

Sl.No.	Terminal voltage 'V'(Volts)	Load current $I_L$	Shunt field current ( $I_{sh}$ ) kept constant	Armature current $I_a = I_L + I_{sh}$	Induced emf $E = V + I_a R_a$	Remarks
						Armature resistance = ohms

**Remember**

- 8 Determine open circuit voltage  $V = E - I_a \cdot R_a$  where E is the induced emf  
 $I_a$  is the armature current  
 $R_a$  is the armature resistance.

- 9 Determine the armature current  $I_a = I_L + I_{sh}$  where  $I_L$  is the load current  
 $I_{sh}$  is the field current.

In the case of no load  $I_L = 0$   
hence  $I_a = I_{sh}$ .

Therefore, at no load, the terminal voltage comes to  $V = E - (0 + I_{sh}) \cdot R_a$ .

- 10 Close the load switch and gradually load the generator by switching 'ON' a few lamps.
- 11 Read the corresponding terminal voltage, shunt field current, load current, and record them in Table 1.

**Check the speed of the generator at intervals, and adjust it to the rated value.**

- 12 Increase the load current up to 125% of its rated value in 6 or 8 equal steps.

- 13 Note down the corresponding terminal voltage and field current for each step of load current in Table 1.
- 14 Gradually reduce the load current to zero and switch 'OFF' the load circuit and the prime mover.
- 15 Show the record of your readings to the instructor and get his approval.
- 16 Draw the graph of the external characteristic of a DC shunt generator by keeping the terminal voltage in the Y-axis and the load current in the X-axis. (Fig 2)
- 17 Show the graph to your instructor and get his approval.
- 18 Disconnect the circuit.

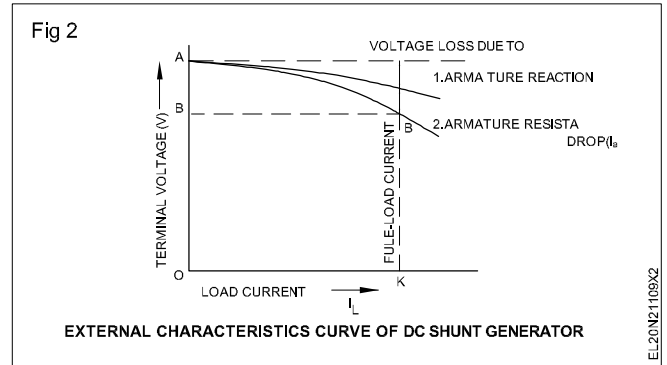

**Test for continuity and insulation resistance of DC machine**

**Objectives:** At the end of this Exercise you shall be able to

- test a DC machine for continuity with a megger
- test a DC machine for insulation resistance between windings with a megger
- test a DC machine for insulation resistance between windings and body with a megger.

Requirements	
<p><b>Tools/Instruments</b></p> <ul style="list-style-type: none"> <li>• Insulated cutting pliers 150 mm - 1 No.</li> <li>• Megger 500V - 1 No.</li> <li>• Screwdriver 150 mm - 1 No.</li> <li>• D/E spanner set 5 to 18mm - 1 Set</li> </ul>	<p><b>Equipment/Machines</b></p> <ul style="list-style-type: none"> <li>• DC compound machine of any rating - 1 No.</li> </ul> <p><b>Materials</b></p> <ul style="list-style-type: none"> <li>• PVC Insulated flexible copper cable 24/0.2 mm - 4 m</li> <li>• Crocodile clips 16 amps - 2 Nos.</li> </ul>

**PROCEDURE**

**TASK 1: Test a DC machine for continuity**

- 1 Switch off the designated main switch of the DC machine and remove the fuse-carriers.
- 2 Identify the pairs of the terminals from the marking.
- 3 Test the continuity of the armature terminals A<sub>1</sub> and A<sub>2</sub>. (Fig 1)
- 4 Test the continuity of the series field terminals D<sub>1</sub> and D<sub>2</sub> using a Megger.
- 5 Test the continuity of the shunt field terminals E<sub>1</sub> and E<sub>2</sub> using a Megger.

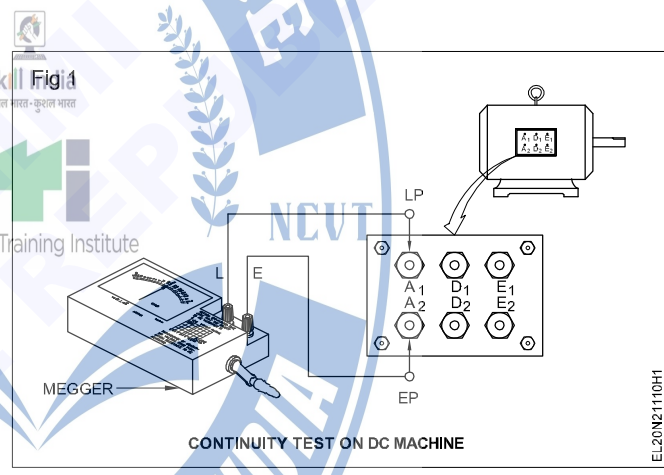

**TASK 2: Test a DC machine for insulation resistance between windings**

- 1 Fill up the columns 1 to 4 in Table 1.
- 2 Connect the Megger between armature and shunt field terminals.
- 3 Rotate the Megger at its rated speed, and note down the reading in Table 1.
- 4 Repeat step 3 for testing the insulation between the shunt field and series field after connecting the Megger terminals.
- 5 Connect the Megger to measure the insulation resistance between the armature and series field.

**The measured value should not be less than 1 megohm.**

Table 1

## Insulation resistance test between windings of a DC machine

Date	Time	Weather condition	Duty cycle	Test between terminals	Insulation resistance in megohms	Remarks
1	2	3	4	5	6	7
				Armature and shunt field		
				Shunt and series field		
				Series field and armature		

## TASK 3: Test a DC machine for insulation resistance between armature/winding and body

- Fill up the columns 1 to 4 in Table 2
- Connect the Megger between the armature and body and repeat step 3 of Task 2, and note down the reading in Table 2.
- Connect the Megger between the series winding and body and repeat step 3 of Task 2, and note down the reading in Table 2.
- Connect the Megger between the shunt winding and body and repeat step 3 of Task 2, and note down the reading in Table 2.
- Show the results to your instructor and get his approval.

If any reading is zero ohms, it shows a short circuit of that winding to the body.

If the reading is less than one megohm, it shows that the insulation is weak. If the value is less than one megohm, inform your instructor immediately so that the necessary remedial steps could be taken to improve the insulation resistance.

Table 2

## Insulation resistance test between armature/field windings and the body of a DC machine

Date	Time	Weather condition	Duty cycle	Test between terminals	Insulation resistance in megohms	Remarks
1	2	3	4	5	6	7
				Armature and the body		
				Series field and the body		
				Shunt field and the body		

**Start, run and reverse direction of rotation of DC series, shunt and compound motors**

**Objectives:** At the end of this Exercise you shall be able to

- connect a 2 point starter and start the motor
- reverse the direction of rotation of a DC series motor
  - by changing the armature terminals.
  - by changing the field terminals.
- connect a 3 point starter to a DC shunt motor, start and run the motor
- reverse the direction of rotation of a DC shunt motor
  - by changing the armature terminals
  - by changing the field terminals
- connect, start and run a DC compound motor through a 4 point starter
- reverse the direction of rotation of a DC compound motor
  - by changing the armature connections (method 1)
  - by changing the shunt field and series field connections (method 2).

Requirements	
<b>Tools/Instruments</b>	
<ul style="list-style-type: none"> <li>• Insulated cutting pliers 150mm - 1 No.</li> <li>• Megger 500 V - 1 No.</li> <li>• Screwdriver 150mm - 1 No.</li> <li>• D.E. spanner set 5mm to 20mm - 1 Set</li> <li>• Shunt type ohmmeter 0-2K or multi meter - 1 No.</li> <li>• Test lamp with 220V 25W lamp - 1 No.</li> <li>• Revolution counter cyclometer 4 digits - 1 No.</li> <li>• Stop watch 30 minutes - 1 No.</li> </ul>	<ul style="list-style-type: none"> <li>• Loading arrangement or complete brake test arrangement - 1 Set</li> <li>• D.C shunt motor 220V 3HP - 1 No.</li> <li>• I.C.D.P switch 250V/16A - 1 No.</li> <li>• 3 Point starter suitable for 220V 3HP D.C shunt motor - 1 No.</li> <li>• Motor compound DC 220Volts and 2 to 3HP - 1 No.</li> <li>• 4 Point starter 220V 16A - 1 No.</li> </ul>
<b>Equipments/Machines</b>	
<ul style="list-style-type: none"> <li>• DC series motor 220V 3 H.P - 1 No.</li> <li>• 2-point starter for 220V 3 H.P. DC series motor - 1 No.</li> </ul>	<ul style="list-style-type: none"> <li>• 2.5sq mm P.V.C. copper multi-strand cable - 18 m</li> <li>• Fuse wire 15 amps - as reqd.</li> </ul>

**PROCEDURE**

**TASK 1: Connect, start and run a DC series motor**

1 Fix and arrange a suitable load for the series motor.

**The series motor should not start or run without a load. A flat belt drive, which might slip, while running should not be used. Fig 1 shows the loading through brake arrangement. The belt over the pulley should be marginally tightened to apply a certain load on the motor.**

2 Select a proper rating of the I.C.D.P. switch, cables, fuse wire and 2-point starter, according to the rating of the given DC series motor.

**The rating of the switch, fuse, cable and 2-point starter given here is for a 220 V 3 HP DC series motor.**

3 Open the 2-point starter, identify the parts, trace the connection and draw the connection diagram.

4 Connect the motor as per a circuit diagram (Fig 1) and get it approved by the instructor.

**Check whether the belt is in position for loading the pulley.**

5 Switch 'ON' the I.C.D.P. and move the 2-point starter gradually in the clockwise direction, till the 'ON' position is reached and observe the direction of rotation.

6 Record the direction of rotation in Table 1.

7 Measure the speed with a tachometer and enter the value in Table 1.

Table 1

Sl. No.	Figure	Direction of rotation	Speed in r.p.m.
1	Fig 1		
2	Fig 2		
3	Fig 3		
4	Fig 4		

8 Stop the motor by switching off the I.C.D.P. and wait till the starter handle comes to the 'OFF' position. Remove the fuse.

**If the 2-point starter provided to you is without the hold on coil and spring-loaded handle, then the starter handle needs to be brought to the 'OFF' position manually after switching 'OFF' the supply.**

**When reversing any motor, we should allow it to come to a dead stop and then operate it in the opposite direction.**

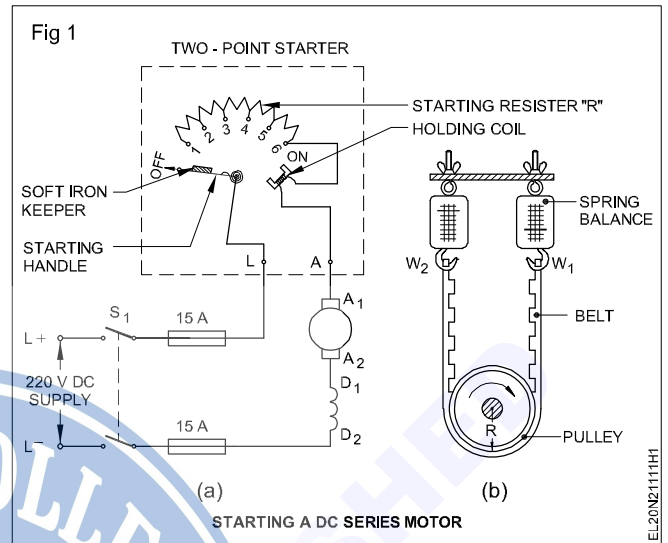

**TASK 2 : Reverse the direction of rotation of a DC series motor**

**METHOD 1 : Reverse the direction of rotation by changing the armature terminals**

1 Repeat steps 5 to 8 of Task 1. (Fig 1)

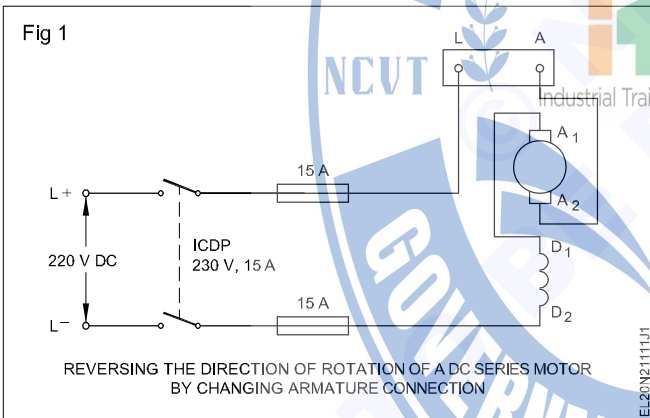

**METHOD 2 : Reverse the direction of rotation by changing the field terminals.**

1 Repeat steps 5 to 8 of Task 1. (Fig 2)

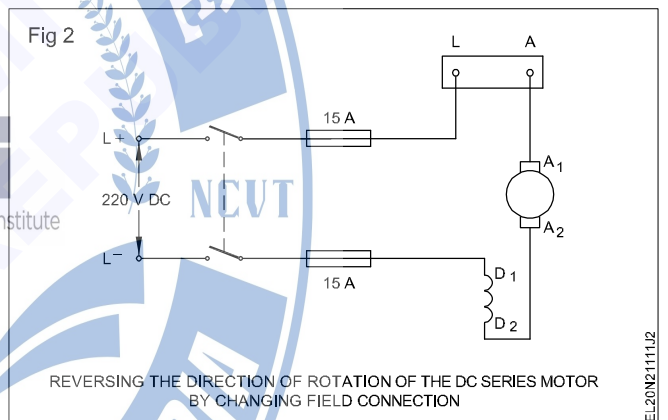

2 Change the supply terminals as per circuit diagram and the loading arrangements for correctness. Repeat steps 5 to 8 of Task 1.

3 Compare the connections. Check the direction of rotation in both the cases.

4 Write the conclusion based on this experiment in the space given below.

**Conclusion**

**TASK 3: Connect, start and run a DC shunt motor**

1 Select the ICDP switch, 3-point starter, fuse wire and cable according to the given specification.

**The specification here is for DC shunt motor 220v, 3HP rating. If the available DC shunt motor in the shop floor is not of the same rating, the specification will have to be changed.**

2 Open the 3-point starter, trace the connections and sketch the internal parts.

3 Measure the resistance of the series resistor and the no-volt coil of the starter. Enter these values in Table 2.

4 Connect the DC shunt motor as per circuit diagram. (Fig 1)

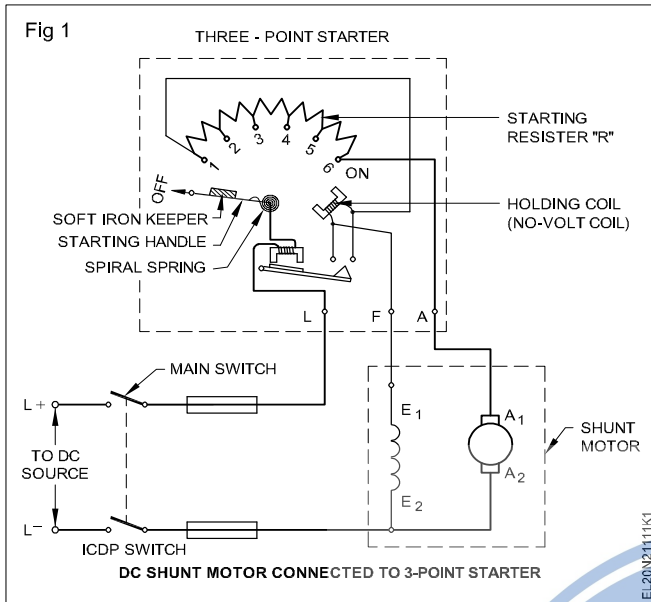

- 5 Check the supply voltage and confirm by verifying with the data given in the name-plate.
- 6 Check the rating of the fuses in the main switch. If required, change it in accordance with the motor rating.
- 7 Switch 'ON' the ICDP and gradually move the starter handle to the 'ON' position.
- 8 Check the direction of rotation and enter it in Table 3.
- 9 Stop the motor by switching 'OFF' the ICDP. Wait until the shaft comes to a standstill position.
- 10 Remove the fuse-carriers from the ICDP.

Table 2

Resistance of the series resistor (in ohms)	Resistance of the no-volt coil (in ohms)

Table 3

Sl.No	Description	Direction of rotation
1	Normal connection	
2	By changing armature terminals	
3	By changing shunt field terminals	

#### TASK 4: Reverse the direction of rotation of a DC shunt motor

##### METHOD 1: Change the direction of rotation by changing the armature terminals.

- 1 Reconnect the DC shunt motor as per circuit diagram. (Fig 1)

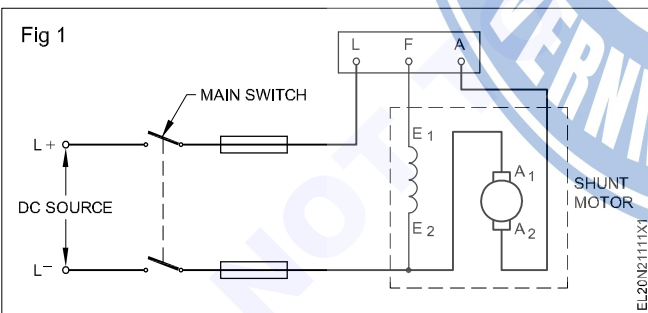

- 2 Replace the fuse-carriers.
- 3 Repeat the working steps 7 to 10 of Task 3.

##### METHOD 2: Change the direction of rotation by changing the shunt field terminals.

- 1 Reconnect the DC shunt motor as per circuit diagram. (Fig 2)

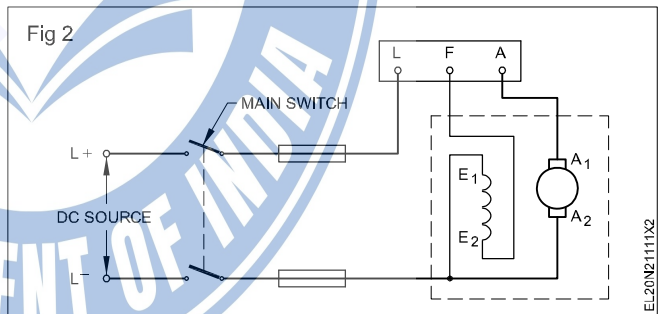

- 2 Replace the fuse-carriers.
- 3 Repeat the working steps 7 to 10 of Task 3.

**Only one pair of terminals, either armature or shunt field, should be changed. If both the armature and shunt field terminals are changed, the direction of rotation will not change.**

Write the conclusion:

- a Necessity of starter
- b Method of changing the direction of rotation in a DC shunt motor based on Fleming's left hand rule.

### TASK 5: Connect, start and run a DC compound motor

- 1 Read and interpret the name-plate details of the given DC compound motor and record it.
- 2 Identify the terminals, and test for the insulation resistance of the given DC compound motor.
- 3 Select proper sizes of switch, starter and cables according to the rating of the given DC compound motor.

**The ratings of the switch, starter, cables etc. given here are for a DC compound motor of 220V 3 HP rating. If the motor rating changes, the rating of the switch, starter, cable etc. should also be changed.**

- 4 Select and insert a suitable fuse wire in the main ICDP switch according to the rating of the given motor.
- 5 Give the connections as per circuit diagram. (Fig 1)

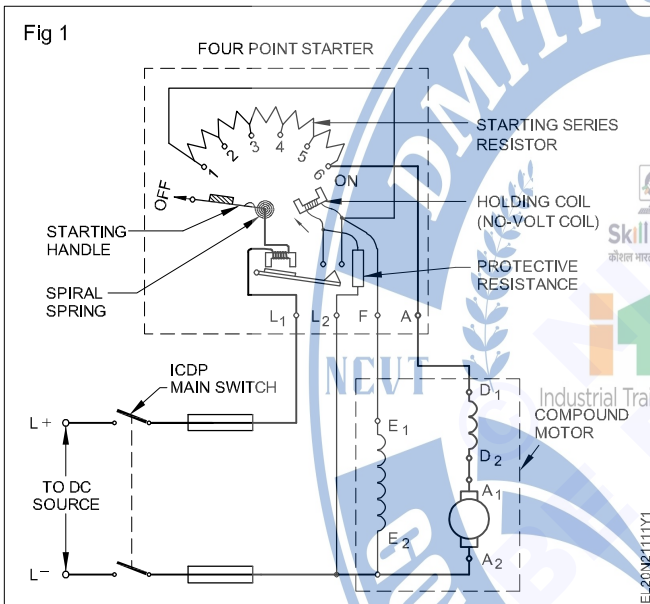

- 6 Connect the ICDP switch to the rated DC supply voltage of the motor.
- 7 Switch on and move the 4-point starter handle slowly until the 'ON' position is reached.
- 8 Observe the direction of rotation of the motor. The direction of rotation of the motor is \_\_\_\_\_

- 9 Take the revolution counter, set the readings to zero, and fix the rubber tip.
- 10 Take the stopwatch and set its reading to zero.

**The rubber tip of the revolution counter should be engaged to the shaft centre of the motor. The revolution counter and the stopwatch need to be started at the same time and stopped at the same time.**

- 11 Hold the revolution counter in the right hand and the stopwatch in the left hand.
- 12 Engage the rubber tip of the revolution counter in the centre of the shaft of the motor.

**Stand away but in front of the shaft and engage the rubber tip slowly in the small countersink position of the rotating shaft.**

- 13 Press the start-button of the revolution counter and the stopwatch simultaneously.
- 14 Press the 'off' button of the stopwatch just when the stopwatch reads one minute and the revolution counter simultaneously. Read the revolution per minute. Speed of the motor in revolution per minute is \_\_\_\_\_

**If you are not able to stop the stopwatch exactly in one minute, follow the procedure given below. (However the stopwatch and the revolution counter ought to have been stopped at the same time)**

'N' Number of revolutions recorded in counter for a time of 'X' minutes as recorded by the stopwatch.

Revolution per minute =

$$\frac{\text{'N' Number of revolutions in counter}}{\text{Stopwatch time in 'X' minutes}} = \text{r.p.m.}$$

- 15 Stop the motor by switching off the I.C.D.P; wait till the shaft comes to rest.

### TASK 6: Reverse the direction of rotation of a DC compound motor

#### METHOD 1: Reverse the direction of rotation of the DC compound motor by changing the armature connection

- 1 Interchange the terminal of the armature. (Fig 1)

- 2 Switch 'ON' and start the motor by the starter; observe the direction of rotation. The direction of rotation of the motor is \_\_\_\_\_.

- 3 Stop the motor by switching off the I.C.D.P; wait until the motor stops completely.

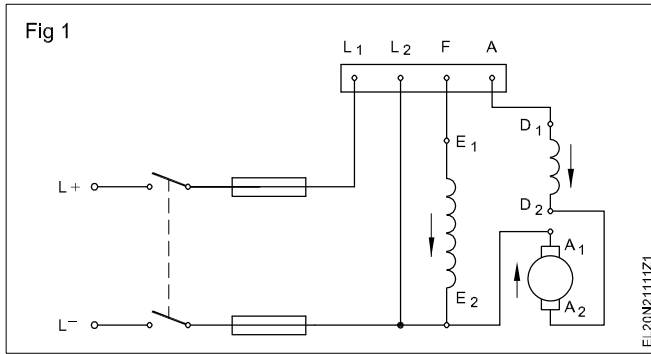

**METHOD 2: Reverse the direction of rotation of the DC compound motor by changing the shunt field terminals and series field terminals.**

**As explained, the series field terminals also need to be changed in this case, to retain the earlier characteristics of the compound motor.**

1 Interchange the field terminals. (Fig 2).

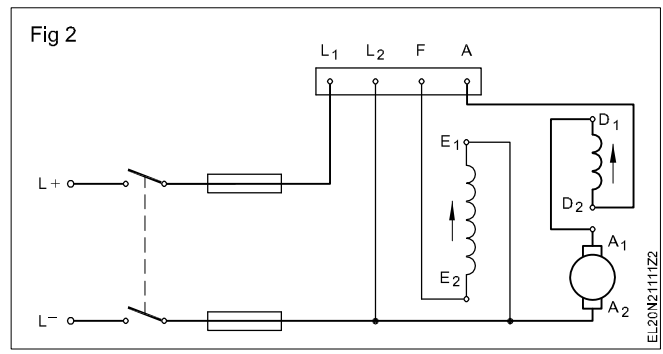

2 Switch 'ON' and start the motor by the starter and observe the direction of rotation. The direction of rotation of the motor is \_\_\_\_\_

3 Switch off the supply. Write your observation regarding the method of changing the direction of rotation of the DC compound motor in the space given below.

4 Show your observations to your instructor.

5 Disconnect the connections and keep the tools, equipment and materials in their proper places.



**Perform no load and load test and determine characteristics of series and shunt generators**

**Objectives:** At the end of this Exercise you shall be able to

- conduct no load test of a DC series generator
- conduct load test and characteristics of a series generator
- conduct no load test of a DC shunt generator
- perform load test and characteristics of the shunt generator.

Requirements	
<p><b>Tools/Instruments</b></p> <ul style="list-style-type: none"> <li>• Combination pliers 200mm - 1 No.</li> <li>• Screw driver 150 mm - 1 No.</li> <li>• Electricians knife 100mm - 1 No.</li> <li>• Revolution counter 4 digits - 1 No.</li> <li>• Stop watch - 1 No.</li> <li>• M.C ammeter 0 to 5A 250V - 1 No.</li> <li>• M.C voltmeter 0-300V - 1 No.</li> <li>• M.C ammeter 15A 250V - 1 No.</li> </ul>	<p><b>Equipment/Machines</b></p> <ul style="list-style-type: none"> <li>• DC series generator 2 or 4 KW 220V - 1 No.</li> <li>• DC shunt generator 2 or 4KW 220V - 1 No.</li> <li>• Rheostat 480Ω 1A - 1 No.</li> <li>• Knife switch DPST 20A/250V - 1 No.</li> <li>• Knife switch SPST 16A/250V - 1 No.</li> <li>• Lamp load 220V/5KW - 1 No.</li> </ul> <p><b>Materials</b></p> <ul style="list-style-type: none"> <li>• P.V.C. Insulated cable 2.5 sq.mm - 6 m</li> <li>• Fuse wire 16A - 0.5m</li> <li>• P.V.C Insulated flexible cable 14/0.2 - 2 m</li> </ul>

**PROCEDURE**

**TASK 1: Conduct no load test of a DC series generator**

- 1 Place all the materials and tools on the work bench.
- 2 Read and interpret the name plate details of the given generator.
- 3 Identify the terminals of the given DC series generator.
- 4 Connect the circuit as per Fig 1.

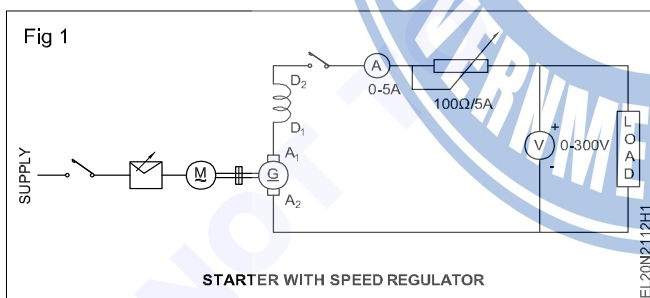

- 5 Start the generator and note down readings.

- 6 Measure the speed of the generator with the help of the revolution counter and stop watch.
- 7 Adjust the prime mover speed such that the generator runs at its rated speed.
- 8 Measure the voltage induced across the armature and note down the measured value in Table 1.
- 9 Increase the field current slowly in steps of 0.1 amperes and for each step note down the field current and the corresponding induced voltage and record them in Table 1.
- 10 Switch off the DC generator and the prime mover.
- 11 Draw the graph keeping the induced voltage in the 'Y' axis and the field current in the x axis.
- 12 Show your readings and graph to your Instructor.

Table 1

Sl. No.	Field current in amps	Induced voltage in volts	Speed (held at constant rated value throughout the experiment)

**TASK 2 : Conduct load test and analyse characteristics of DC series generator**

- 1 Place all the materials and tools on the work bench.
- 2 Connect the circuit as per Fig 1.

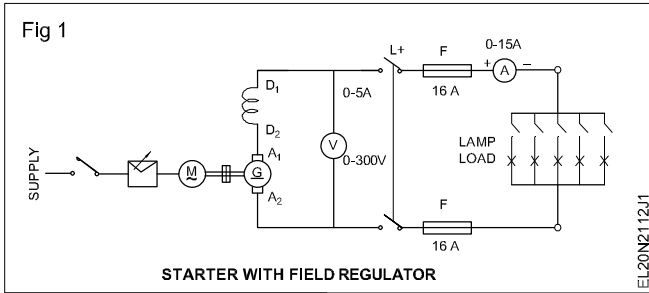

- 3 Keep the main switch at off position.
- 4 Rotate the armature using a prime mover at the rated speed.
- 5 Operate the main switch in ON position.
- 6 Now operate the load switch in ON position.
- 7 Note down the ammeter and voltmeter readings in the Table 2.
- 8 Change the speed of generator and note the different values of ammeter and voltmeter.

- 9 Plot the graph between terminal voltage and load current. (Fig 2)

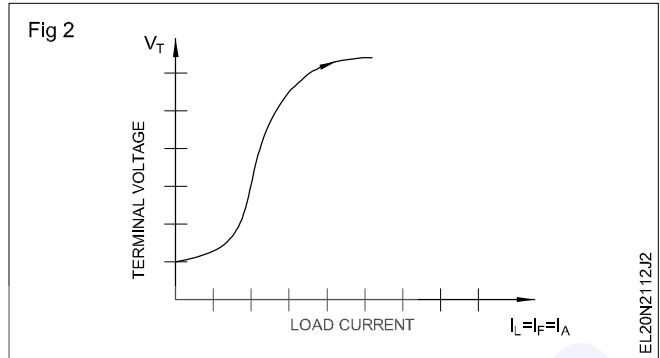
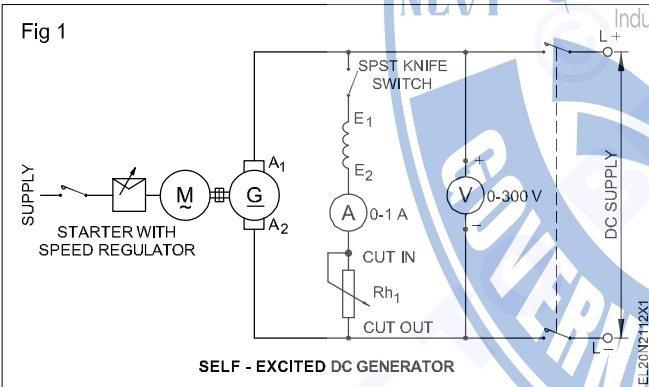

Table 2

Sl No	Load current $I_L$ (in amps)	Terminal Voltage $V_T$ (involts)
1		
2		
3		

**TASK 3: Perform conduct no load test of a shunt generator**

- 1 Identify the terminals of the given DC shunt generator.
- 2 Connect the circuit as per Fig 1.



- 3 Keep the field switch open and the field rheostat in the cut 'in' position. Get the approval of the instructor.
- 4 Start the prime mover coupled to the DC shunt generator.

- 5 Measure the speed of the generator with the help of the revolution counter and stopwatch.

**The direction of rotation must be according to the direction marked on the DC generator. If not, change the direction of the rotation of the prime mover.**

- 6 Adjust the prime mover speed such that the generator runs at its rated speed.

**Keep the speed constant throughout the experiment.**

- 7 Measure the voltage induced across the armature and note down the measured value in Table 3.

- 8 Close the field circuit switch and gradually increase the field current to 0.1 ampere by reducing the resistance of the field rheostat.

Table 3

Sl.No.	Field current in amps	Induced voltage in volts	Speed (held at constant rated value throughout the experiment)

If the generator is not able to build up voltage even though it is running in the marked direction, switch off the prime mover and then interchange the field terminals of the generator. While varying the field rheostat/regulator it should be done positively and slowly in the forward direction. Reverse movement should be avoided.

- 9 Increase the field current slowly in steps of 0.1 ampere, and for each step, note down the field current and the corresponding induced voltage. Record them in Table 3.
- 10 Switch 'OFF' the DC generator and the prime mover.
- 11 Draw the graph keeping the induced voltage in the 'Y' axis and the field current in the X axis.

The graph shows the magnetisation / no-load characteristic of the DC shunt generator.

- 12 Show your readings and graph to your instructor.

13 Answer the following questions.

- a The magnitude of the residual voltage is \_\_\_\_\_
- b When there is no current in the field, how is the residual magnetism available in the poles?
- c What are the reasons for the disappearance of residual magnetism in a DC generator?
- d What is the reason for the magnetisation characteristic curve to have a straight line relationship between the field current and the induced voltage?
- e What is the reason for the magnetisation characteristic curve to have a flat portion in the end?
- f Could you remember the shape of the magnetisation characteristic as a part of a certain other curve which you studied earlier? If yes, write where and how the two curves are related to each other.

#### TASK 4: Conduct load test and analyse characteristics of a DC shunt generator

- 1 Measure the armature resistance and enter the value in Table 4.
- 2 Connect the meters, rheostat and lamp load with the terminals of the DC shunt generator. (Fig 1a) (If a lamp load is not available, a water load (Fig 1b) can be used.)
- 3 Keep the load switch open and also switch 'off' all the circuit switches in the lamp load.
- 4 Keep the field regulator resistance in 'cut-in' position.

Make yourself clear about the method of starting the prime mover and the procedure of adjusting its speed.

- 5 Start the prime mover and bring it to the rated speed of the generator.
- 6 Build up the voltage of the generator to its rated value, by adjusting the field rheostat. Enter the value of the open circuit voltage in Table 4.

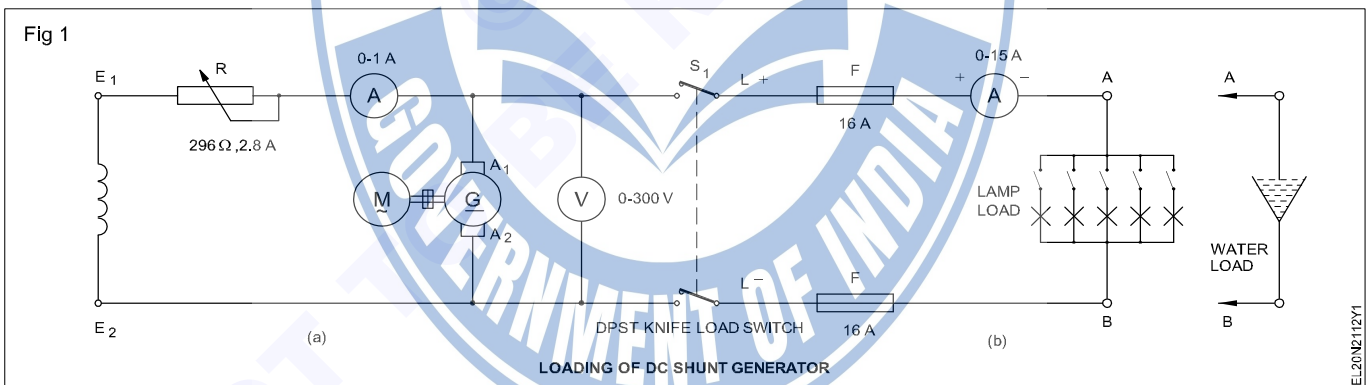

Table 4

Sl.No.	Terminal voltage 'V'(Volts)	Load current $I_L$	Shunt field current ( $I_{sh}$ ) kept constant	Armature current $I_a = I_L + I_{sh}$	Induced emf $E = V + I_a R_a$	Remarks
						Armature resistance = ohms

## Remember

Therefore, at no load, the terminal voltage comes to

$$V = E - (0 + I_{sh}) \cdot R_a.$$

- 7 Close the load switch and gradually load the generator by switching 'ON' a few lamps.
- 8 Read the corresponding terminal voltage, shunt field current, load current, and record them in Table 4.

**Check the speed of the generator at intervals, and adjust it to the rated value.**

- 9 Increase the load current up to 125% of its rated value in 6 or 8 equal steps.
- 10 Note down the corresponding terminal voltage and field current for each step of load current in Table 4.
- 11 Gradually reduce the load current to zero and switch 'OFF' the load circuit and the prime mover.

- 12 Show the record of your readings to the instructor and get his approval.
- 13 Draw the graph of the external characteristic of a DC shunt generator by keeping the terminal voltage in the Y-axis and the load current in the X-axis. (Fig 2)
- 14 Show the graph to your instructor and get his approval.
- 15 Disconnect the circuit.

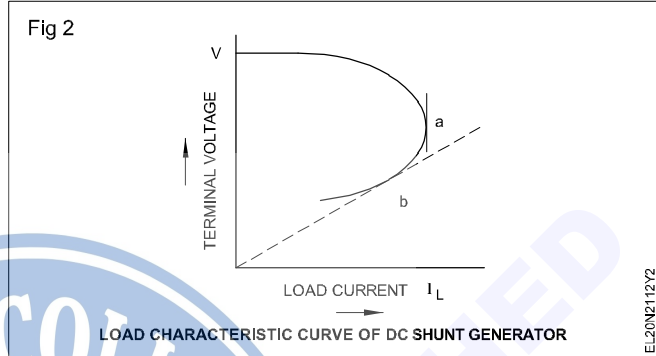

**Perform no load and load test and determine characteristics of compound generators (cumulative and differential)**

**Objectives:** At the end of this Exercise you shall be able to

- connect the DC compound generator as long shunt and then as short shunt
- build up voltage and load the compound generator
- determine the load performance characteristic of a DC compound generator (cumulative and differential).

Requirements	
<b>Tools/Instruments</b> <ul style="list-style-type: none"> <li>• Combination pliers 200mm - 1 No.</li> <li>• M.C. voltmeter 0-250V - 1 No.</li> <li>• Screwdriver 150mm - 1 No.</li> <li>• M.C. ammeter 0-20A - 1 No.</li> <li>• Electrician's knife - 1 No.</li> <li>• Rheostat 296 ohms 2.8 amp - 1 No.</li> </ul>	<b>Equipment/Machines</b> <ul style="list-style-type: none"> <li>• DC compound generator 220V 4KW - 1 No.</li> <li>• Lamp load/resistance load/water load of capacity 220V 5KW - 1 No.</li> </ul> <b>Materials</b> <ul style="list-style-type: none"> <li>• PVC Insulated copper cable 4 sq mm - 5 m</li> <li>• DPST knife switch 16A 240V - 1 No.</li> </ul>

**PROCEDURE**

**TASK 1: Connect, build up and determine the load performance characteristic of a DC long shunt compound generator : (a) cumulative (b) differential.**

- 1 Connect the machine as per the connection diagram. (Fig 1)
- 2 Provide a suitable fuse according to the rating of the DC compound generator.
- 3 Start the prime mover coupled to the DC compound generator, and build up the voltage of the DC compound generator to its rated value.
- 4 Switch 'ON' the load.
- 5 Increase the load step by step, note the values of the terminal voltage and load current for each step, and enter them in Table 1.

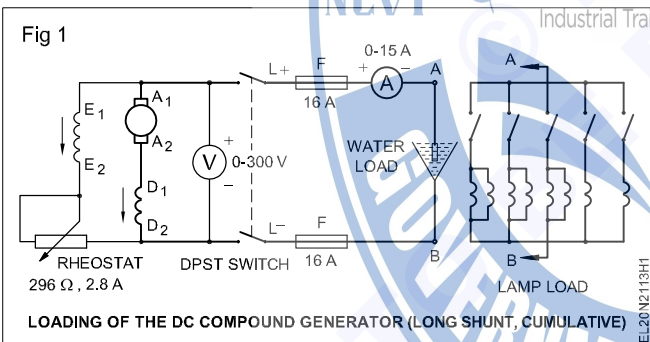

Table 1  
**Long shunt compound generator**

I EXERCISE			II EXERCISE		
Sl.No	Load current	TPD	Sl.No	Load current	TPD
<b>Type of connection</b>			<b>Type of connection</b>		

**To check whether the compound generator is connected for cumulatively compound or differentially compound which will not be easy at this stage. But this could be determined after loading.**

- 2 Provide a suitable fuse according to the rating of the DC compound generator.

**Keep the load switch and all the load sub-circuit switches open.**

**Keep the field rheostat sliding arm in such a position that the maximum value of resistance is included in the field circuit.**

- 6 Draw the external characteristic curve keeping the load current in the 'X'-axis and the terminal voltage of the generator in the 'Y'-axis.
- 7 Open the load switch and stop the prime mover.
- 8 Interchange the connections of the series field. (Fig 2)

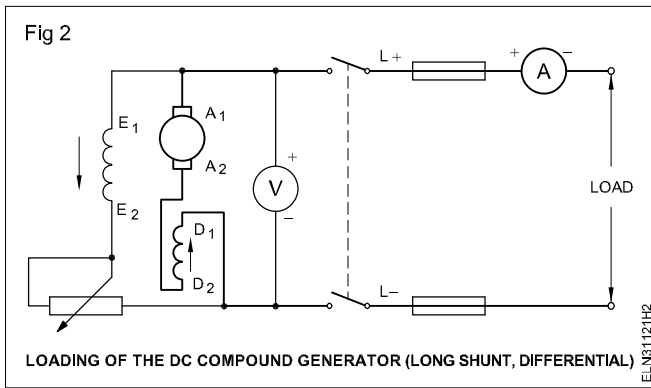

- 9 Repeat the working steps 6 to 9 and draw the external characteristic curve for the second set of readings in the same graph sheet.
- 10 Write clearly which one of the graph is for the cumulatively compounded generator, and which one is for the differentially compounded generator.

**TASK 2: Determine the load performance of DC short shunt compound generator : a) Cumulative b) Differential**

- 1 Check connections (Fig 1&2 from Task 1) are for a long shunt compound generator.

**Complete the connection diagrams shown in Figs 1a and 1b for the short shunt cumulative, and differential compound generator, and get it approved by the instructor.**

- 2 Repeat the experiment for the short shunt cumulative and differential compound generators following steps 5 to 13 of Task 1, and enter the values in Table 2.
- 3 Draw the external characteristic curves on a separate graph sheet in the same scale as in the earlier graphs, and compare with them.

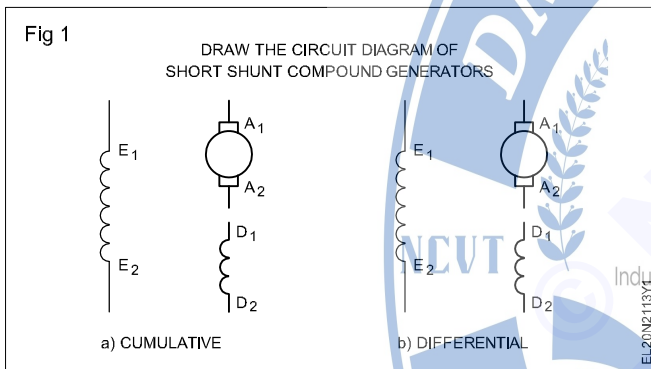

Table 2

Short shunt compound generator					
I EXERCISE			II EXERCISE		
Sl.No	Load current (Amps)	TPD Volt	Sl.No	Load current (Amps)	TPD volt
1					
2					
3					
4					
Type of connection			Type of connection		

**Practice dismantling and assembling in DC shunt motor**

**Objectives:** At the end of this Exercise you shall be able to

- read and interpret the name-plate details of a DC shunt motor
- conduct visual inspection of the Power machine
- dismantle the DC shunt motor
- remove, inspect and install the bearings
- clean the parts of DC shunt motor
- reassemble the DC shunt motor
- adjust the brush tension and bedding of brushes, and correct the rocker arm position
- check the performance of DC shunt motor.

Requirements	
<p><b>Tools/Instruments</b></p> <ul style="list-style-type: none"> <li>• Pulley puller 6" - 1 No.</li> <li>• Hammer 500 gms - 1 No.</li> <li>• Cutting pliers 200mm - 1 No.</li> <li>• Centre punch 100mm. length - 1 No.</li> <li>• Spanner set 5mm to 20mm - 1 Set.</li> <li>• Screwdriver, heavy duty - 200 mm</li> <li>• Tray 300 x 300 mm x 50 mm - 1 No.</li> <li>• Mallet, hardwood 60mm dia. - 1 No.</li> <li>• "Man on line" board - 1 No.</li> <li>• Electric blower - 250V 50HZ - 1 No.</li> </ul> <p><b>Equipment/Machines</b></p> <ul style="list-style-type: none"> <li>• DC Shunt motor - 1 No.</li> </ul>	<p><b>Materials</b></p> <ul style="list-style-type: none"> <li>• Kerosene - 1 litre</li> <li>• Cotton cloth - 1/4 sq.m.</li> <li>• Carbon tetrachloride - 100 ml.</li> <li>• Round brush for cleaning 2cm - 1 No.</li> <li>• Petrol - 200 ml.</li> <li>• Sand paper No.1 - 1 Sheet</li> <li>• Hacksaw blade 300 mm - 3 Nos.</li> <li>• Sand paper 'oo' smooth - 1 Sheet</li> <li>• Mobile oil S.A 40 - 1/2 litre</li> <li>• Cotton waste - 100 gms</li> <li>• Shell alvania 3 grease or equivalent - 100 gms</li> <li>• Hardwood 3cm sq. 20cm long - 2 Pieces</li> </ul>

**PROCEDURE**

- 1 Read the manufacturer's instruction booklet, and particularly take into account any special instructions regarding dismantling procedures.
- 2 Remove the fuse-carriers from the main switch, disconnect the DC machine from the supply and display the "Man-on-line board" on the main switch.
- 3 Remove the foundation bolts of the machine, shift the machine to the workbench and note the name-plate details in Table 1 as shown is Exercise 2.1.107
- 4 Conduct a visual inspection.
- 5 Clean the outside surface of the motor. Remove all dirt and grease with a dry cloth soaked in petrol/kerosene.

**Do not use water.**

- 6 Make punch marks on both the end plates and yoke. (Fig 1)
- 7 Mark the rocker arm position with respect to the end plate.
- 8 Remove the brushes from the brush-holder.
- 9 Check pulley tightness and adjust. Remove pulley it with a pulley puller if the pulley is found tightly fitted.

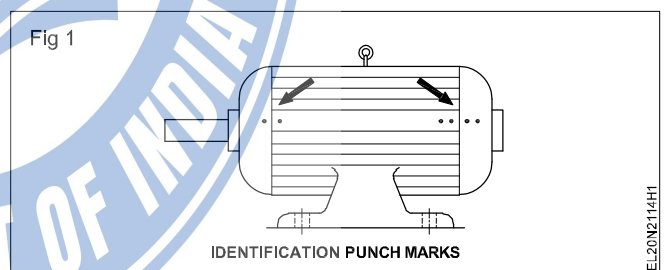

- 10 Remove the grease cup stud and open the grease cup. (Fig 2)

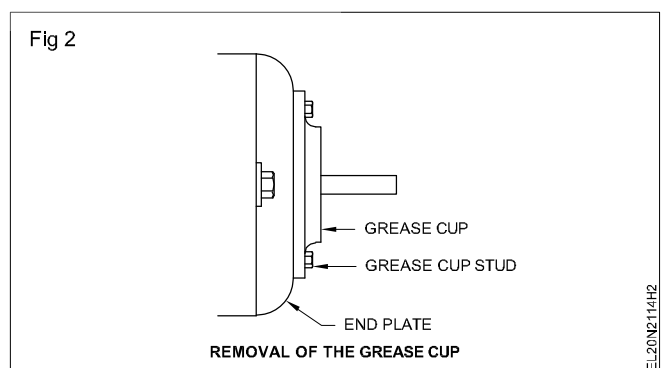

11 Loosen the studs of both the end plates and then remove the end plate of the shaft side.

**Open one end of the end plate slowly by holding the armature shaft by hand or pulley block so that the weight of the armature does not damage the pole faces or field windings.**

12 Remove the armature from the body of the machine. (Fig 3)

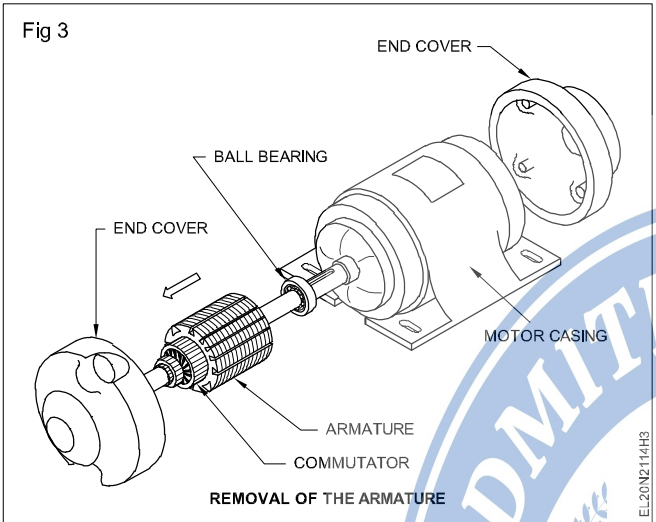

13 Remove the bearings using a bearing puller.

**New bearings need no cleaning. Do not remove the new bearings from the package until needed. Before opening the new bearing, keep the workbench clean and tidy. For fixing the bearing in the shaft, follow the guidelines (Fig 4).**

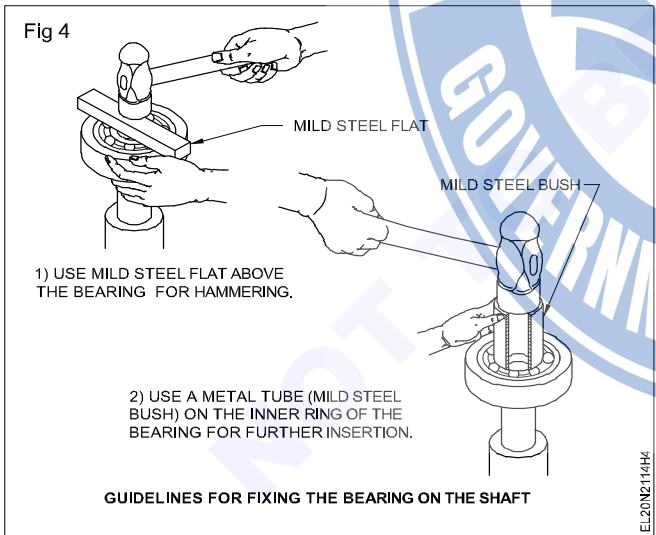

14 Reassemble the yoke, armature and end plates.

15 Check the freeness of the shaft by rotating the shaft by hand.

**If found tight (not free) loosen the end-plate studs and tighten the crosswise studs gradually in the proper sequence, and at the same time feeling the shaft for free rotation.**

16 Insert the brush in the holder, adjust the brush tension, and bed the brushes following the procedure shown in Fig 5.

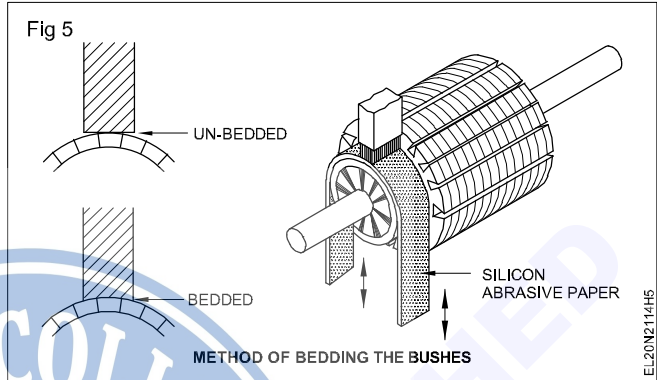

17 Position the rocker-arm in the end plates as per original marking.

18 Re-install the machine in the foundation and tighten the foundation bolts and connect the motor to the supply.

19 Check whether the motor is operating smoothly without any vibration. A check-list for mechanical functions is given in Table 1. Fill up all the possible columns after checking the motor operation.

Table 1

Sl. No.	Check-list (Mechanical)	Remarks
1	Noise	
2	End-play	
3	Rotor running free	
4	Bearing fits	
5	Lubrication, grease, nipples oil supply	
6	Temperature bearings	
7	Temperature motor frame	
8	Condition of shaft, keyway, pulley, bearing seals	
9	Bolts, nuts tightened	
10	Test run 30 min	

**Practice dismantling and assembling in DC compound generator**

**Objectives:** At the end of this Exercise you shall be able to

- read and interpret the name-plate details of a DC compound generator
- conduct visual inspection of the Power machine
- dismantle the DC compound generator
- remove, inspect and install the bearings
- clean the parts of the DC generator
- reassemble the DC compound generator
- adjust the brush tension and bedding of brushes and correct the rocker arm position
- check the performance of DC compound generator.

Requirements	
<p><b>Tools/Instruments</b></p> <ul style="list-style-type: none"> <li>• Pulley puller 6" - 1 No.</li> <li>• Hammer 500 gms - 1 No.</li> <li>• Cutting pliers 200mm - 1 No.</li> <li>• Centre punch 100mm. length - 1 No.</li> <li>• Spanner set 5mm to 20mm - 1 set</li> <li>• Screwdriver, heavy duty - 200 mm</li> <li>• Tray 300 x 300 mm - 1 No.</li> <li>• Mallet, hardwood 60mm dia. - 1 No.</li> <li>• "Man on line" board - 1 No.</li> <li>• Electric blower 240V 50HZ - 1 No.</li> </ul> <p><b>Equipment/Machines</b></p> <ul style="list-style-type: none"> <li>• DC compound generator - 1 No.</li> </ul>	<p><b>Materials</b></p> <ul style="list-style-type: none"> <li>• Kerosene - 1 litre</li> <li>• Cotton cloth - 1/4 sq. m.</li> <li>• Carbon tetrachloride - 100 ml.</li> <li>• Round brush for cleaning 2cm - 1 No.</li> <li>• Petrol - 200 mil.</li> <li>• Sandpaper No.1 - 1 sheet</li> <li>• Hacksaw blade 300 mm - 3 Nos.</li> <li>• Sandpaper 'oo' smooth - 1 sheet</li> <li>• Mobile oil S.A 40 - 1/2 litre</li> <li>• Cotton waste - 100 gms</li> <li>• Shell alvania 3 grease or equivalent - 100 gms</li> <li>• Hardwood 3cm sq. 20cm long - 2 pieces</li> </ul>

**PROCEDURE**

**TASK 1: Dismantle, inspect and reassemble DC compound generator**

- 1 Read the manufacturer's instruction booklet, and particularly take into account any special instructions regarding dismantling procedures.
  - 2 Remove the foundation bolts of the machine and shift the machine to the workbench.
  - 3 Conduct a visual inspection.
- Do not use water.**
- 4 Make punch marks on both the end plates and yoke.
  - 5 Mark the rocker arm position with respect to the end plate.
  - 6 Remove the brushes from the brush-holder.
  - 7 Check pulley tight and adjust.
  - 8 Remove the grease cup stud and open the grease cup.
  - 9 Loosen the studs of both the end plates and then remove the end plate of the shaft side.

**Open one end of the end plate slowly by holding the armature shaft by hand or pulley block so that the weight of the armature does not damage the pole faces or field windings.**

- 10 Remove the armature from the body of the machine.
- 11 Remove the bearings using a bearing puller.
- 12 Reassemble the yoke, armature and end plates.
- 13 Check the freeness of the shaft by rotating the shaft by hand.

**If found tight (not free) loosen the end-plate studs and tighten the crosswise studs gradually in the proper sequence, and at the same time feeling the shaft for free rotation.**

- 14 Insert the brush in the holder, adjust the brush tension, and bed the brushes.

15 Position the rocker-arm in the end plates as per original marking.

16 Re-install the machine in the foundation and tighten the foundation bolts and connect the generator.

17 Check whether the generator is operating smoothly without any vibration. A check-list for mechanical functions is given in Table 1. Fill up all the possible columns after checking the generator operation.

Table 1

Sl. No.	Check-list (Mechanical)	Remarks
1	Noise	
2	End-play	
3	Rotor running free	
4	Bearing fits	
5	Lubrication, grease, nipples oil supply	
6	Temperature bearings	
7	Temperature motor frame	
8	Condition of shaft, keyway, pulley, bearing seals	
9	Bolts, nuts tightened	
10	Test run 30 min	

